

## WIRING AND TROUBLESHOOTING MANUAL

September 2014



240508



E257460

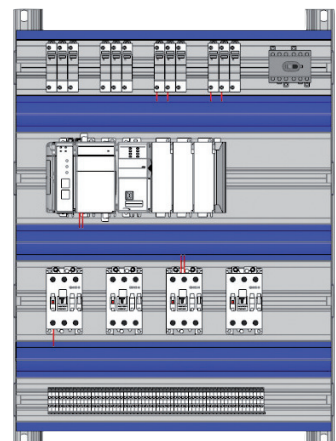



## Table of Contents Wiring and Troubleshooting Manual

<b>1.</b>	<b>Delivery</b> .....	<b>3</b>
<b>2.</b>	<b>Wiring</b> .....	<b>3</b>
<b>2.1</b>	Accessibility .....	<b>3</b>
<b>2.2</b>	Wiring Comb .....	<b>4</b>
<b>2.3</b>	Routing the wire .....	<b>4</b>
<b>2.4</b>	Signal Separation/Segregation .....	<b>5</b>
<b>2.5</b>	Cosmetic finish .....	<b>6</b>
<b>3.</b>	<b>Installation in the enclosure</b> .....	<b>7</b>
<b>3.1</b>	Enclose with shoulder studs .....	<b>7</b>
<b>3.2</b>	Modular enclosure .....	<b>7-8</b>
<b>3.3</b>	Fully threaded studs .....	<b>8</b>
<b>3.4</b>	Unistrut enclosure .....	<b>9</b>
<b>4.</b>	<b>Troubleshooting</b> .....	<b>10-11</b>



**This manual is a guide line for the best practice to wire and troubleshoot Satie panels. You will find below important information on how to wire your Satie panel in the most effective way.**

## 1. Delivery

You will receive your Satie panel frame as a pre-assembled unit. Depending on the size and number of frames ordered, the panel will come boxed or on a skid (**Fig. 1**).

Upon receiving your Satie panel, you can take it out of the packaging and place it on your workbench (**Fig. 2**) the same way you would work with your traditional panel using the wire duct and Din rail.

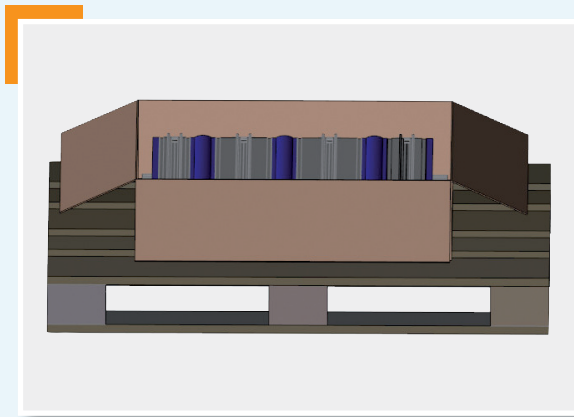

Figure 1

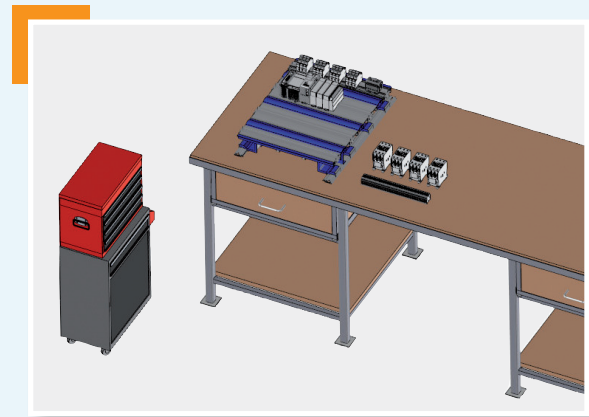

Figure 2

You can populate your panel with the components as per your layout. For the Din rail mountable components the Din rail is already in place. For non-Din rail components they will be mounted using the provided hardware. Otherwise the parts can be mounted in place by drilling and tapping into the aluminum profile.

## 2. Wiring

### 2.1 Accessibility

The first step after populating the frame is to remove the covers (CPF's) between the profiles to gain access to the wire tray (**Fig. 3**).

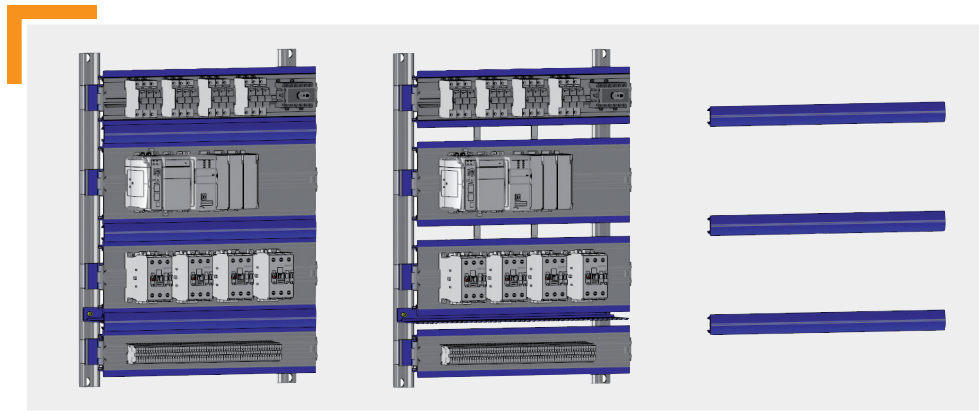

Figure 3





## 2.2 Wiring Comb

One of the great features of the Satie panel frame is the wiring comb (PF300 and PFE300), which is attached above and below each profile to facilitate the wiring. The custom design comb has small and big teeth. For standard control gauge wire (#20 to #14) up to three wires per slot can be accommodated. For heavier gauge wires (up to AWG #4) the small tooth can be cut out and the two bigger ones will compress offering some strain relief (**Fig.4**). If need be you can always cut a piece of the cover to allow the wire(s) to go in between.

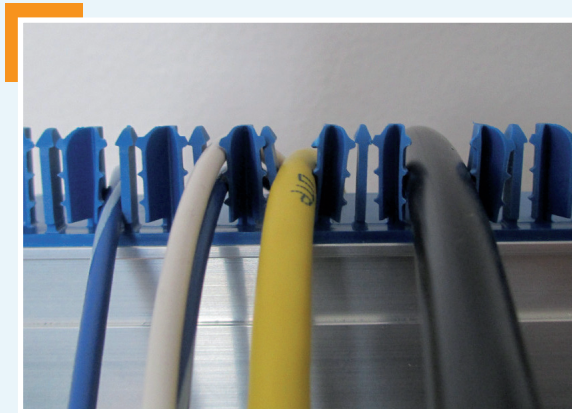
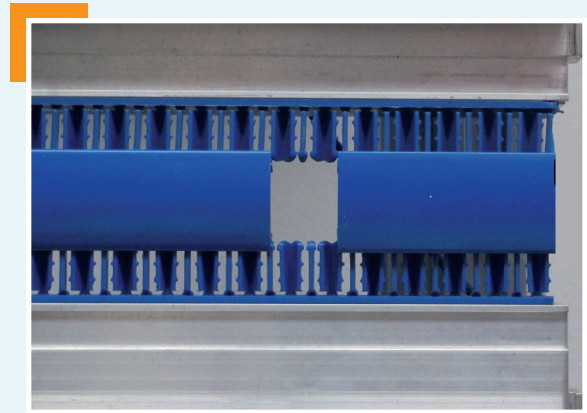

Figure 4



## 2.3 Routing the wire

To go from point A to point B the same rules as the traditional wire ways apply. First snap the wire in the comb (above or below your connection point) as per fig.4.

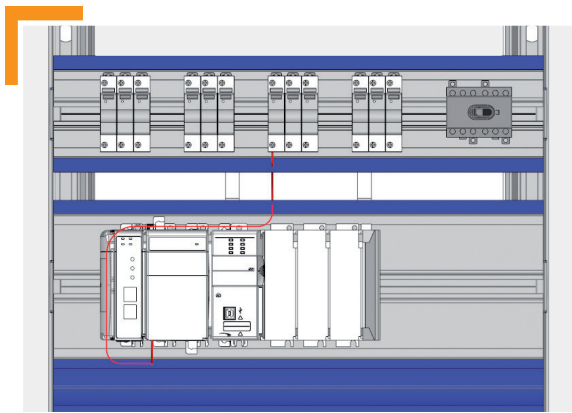

Figure 5

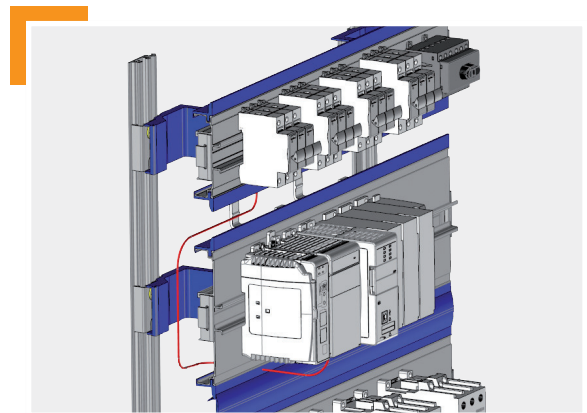

Figure 6

The component access point is easily accessible as nothing is blocking the way. The wire runs horizontally in between the two combs to the left or the right. (**To the left in fig. 6**). Once you have reached the far left (or right) you can route the wire up and down in the U-shaped bracket (EM) until you reach the level of the point B. Then you go left or right horizontally until you reach the connection point B. The pattern is the same as the traditional wire way going horizontally and vertically. The vertical wire ways are now pushed on the side underneath the component level. The wiring is to be done loose as there are no confined section limiting the amount of wire in the tray.





## 2.4 Signal separation/segregation

There are different ways to separate the signal. For a standard separation you can use the left U shape (left vertical wire way) for one type of signal and the right side for the other (**Fig. 7**). Running horizontally, the wire will be held in front of the opening by the wire holder (BC80 or BC45).

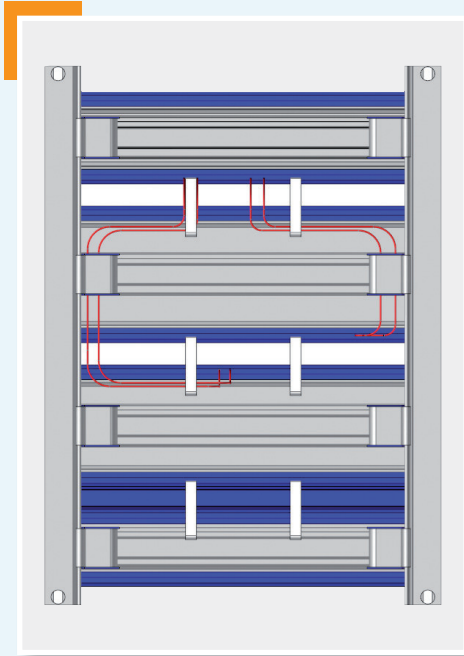

Figure 7



If you need to do a true double ducting and separate the signal horizontally and vertically a half wire duct (HWD80 or HWD45) can be used (**Fig. 8**).

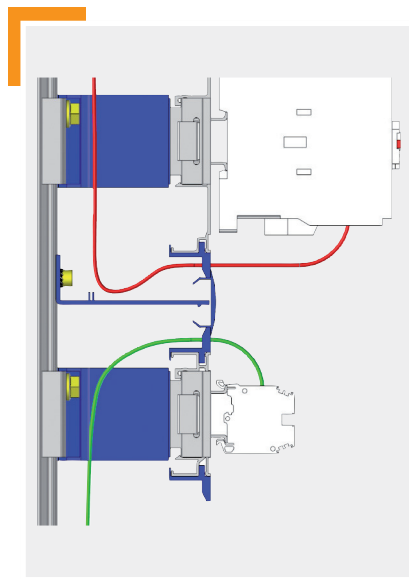
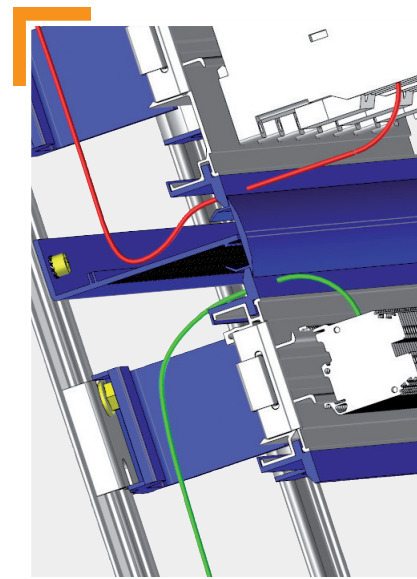

Figure 8





## 2.5 Cosmetic finish

The HDW80 or HDW45 can be used to close the panel at the bottom and contain all the wires for a nice clean finish.

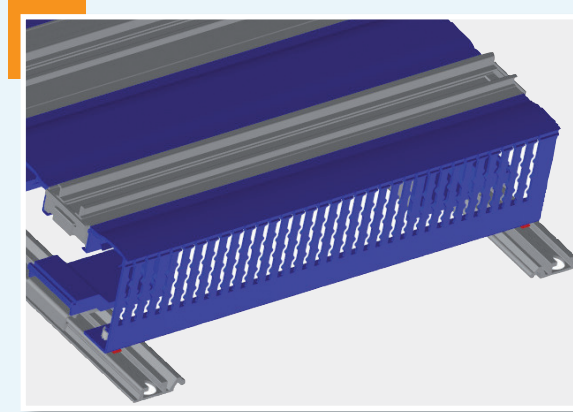

Figure 9

The side cover CEC60 (**Fig. 10 and 11**) closes the gap between the side of the panel and the side of the box. This space can be used to hide any wiring coming from the door or the field – also preventing it from mixing with the existing panel wiring.

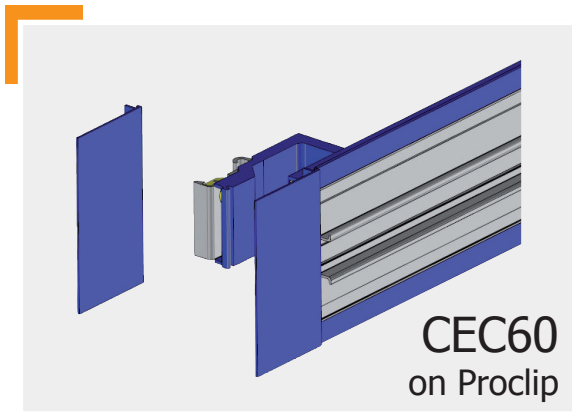

Figure 10

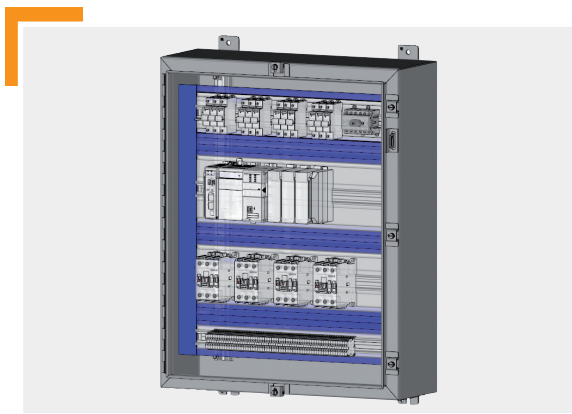
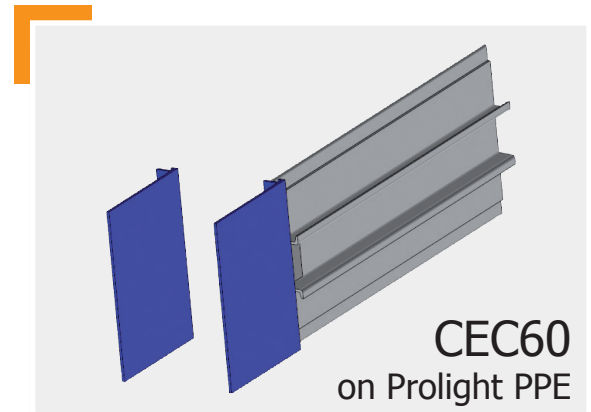

Figure 11





### 3. Installation in the enclosure

#### 3.1 Installation in an enclosure with shoulder studs

Installing the Satie Proclip or Prolight panel frame in the enclosure with shoulder studs is quite simple. By design the pillars that are catching the studs are punched from the back with a  $\frac{3}{4}$ " hole to allow the shoulder to sit on the inside of the groove.



Figure 12



Figure 13

#### 3.2 Installation in a modular enclosure

The installation of the Satie Proclip frame into the modular enclosure is done via the provided bracket depending on the brand of enclosure. The panel can catch the framing at the back, on the side or at the top and bottom.



Figure 14

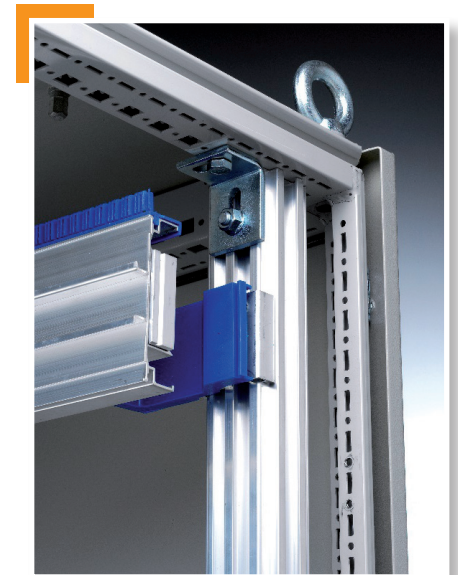

Figure 15



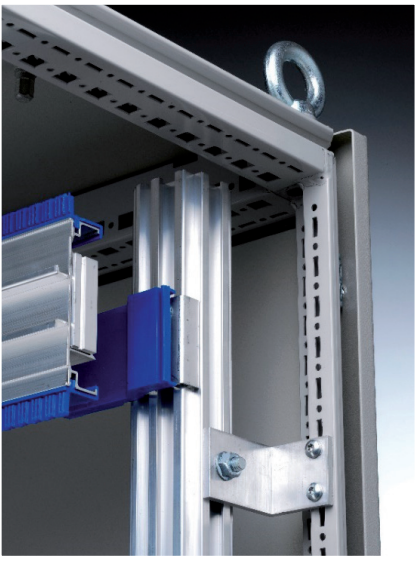

Figure 16

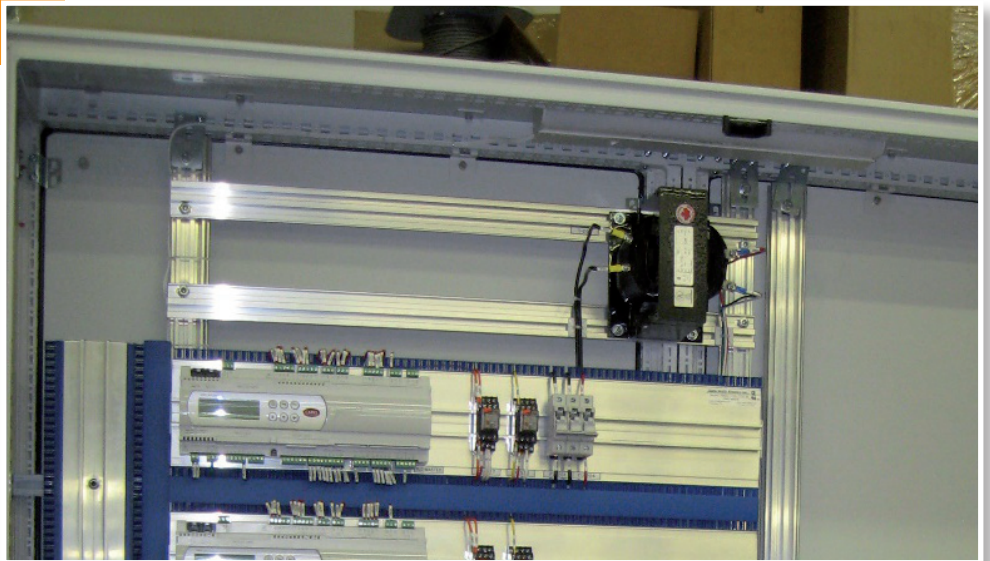

Figure 17

### 3.3 Installation in an enclosure with fully threaded studs

When the studs of the enclosure are fully threaded and longer than  $\frac{3}{4}$ " then we punch the mounting pillars with an 11x22 (0.433"x0.866") oblong that will let the stud go through the profile and the nut is used to clamp the frame in place just like the traditional back panel.

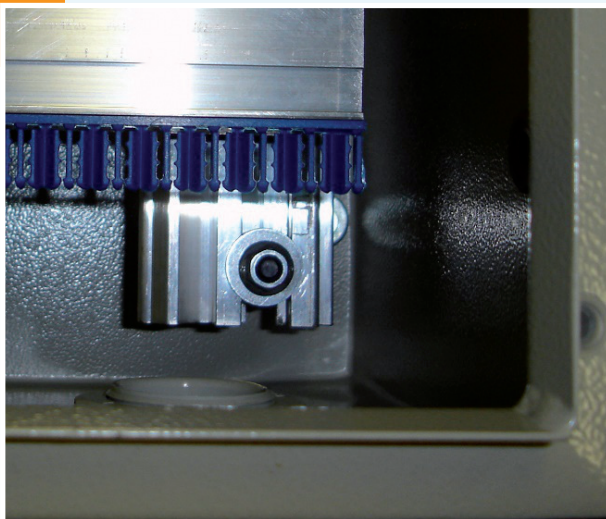

Figure 18

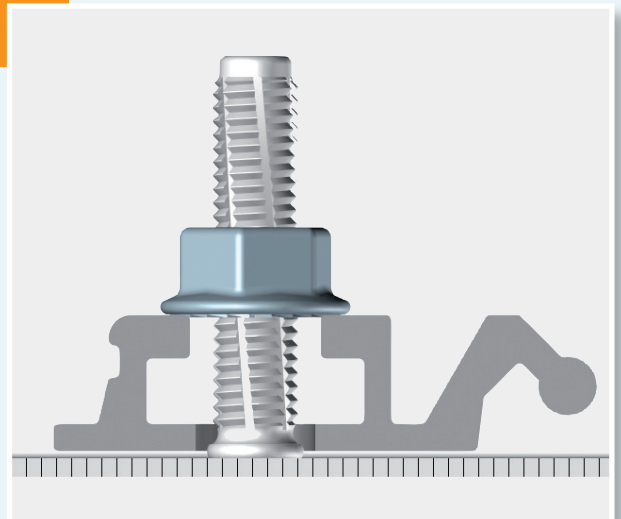

Figure 19



### 3.4 Installation in the enclosure with Unistrut

For the enclosure with Unistrut the Satie frame will be designed to catch the Unistrut using one of our mounting bracket. In the example below we have used EDF S brackets (**Fig. 20 and 21**).

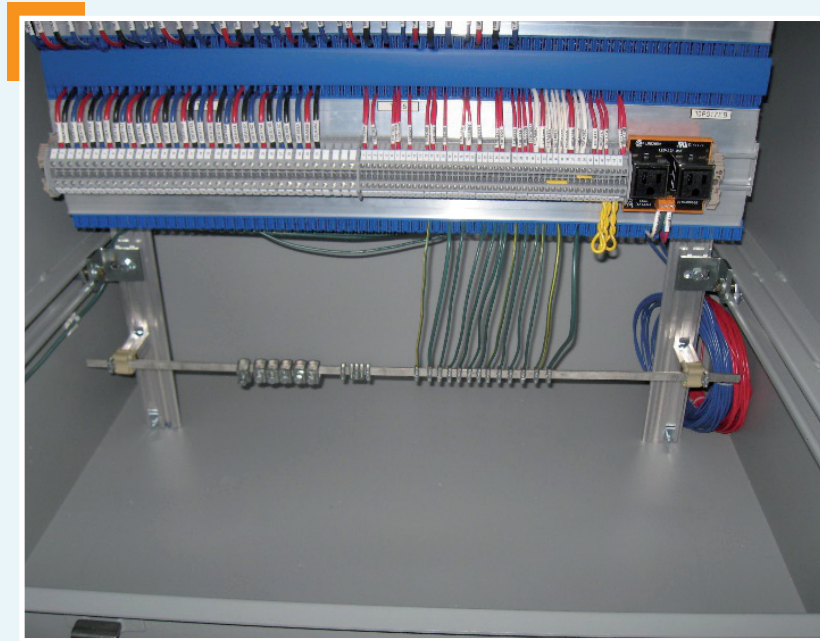

Figure 20



Figure 21



## 4. Troubleshooting

The Satie panel frame can be easily troubleshooted as the wires are not confined in an enclosed duct like the traditional wire ways (**Fig. 7**). The wiring has been done loose without any tie wraps so they can easily be traced. From the first connection point the wire can only go left or right until reaching the U shape bracket on the left or right. The wires are sitting on the wire holder (**BC's fig. 22 and BCH's fig. 23**) in front of the opening.

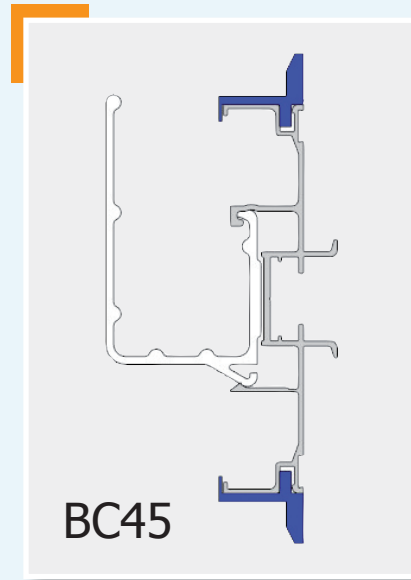
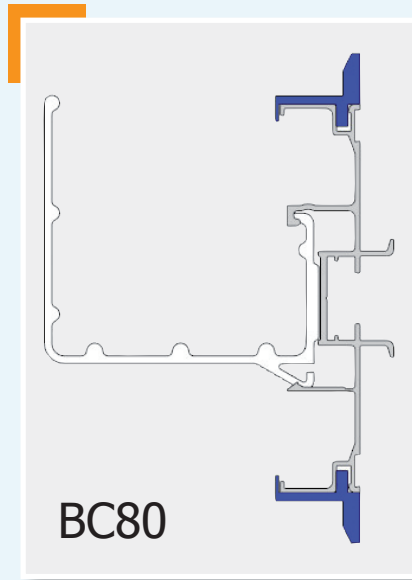

Figure 22

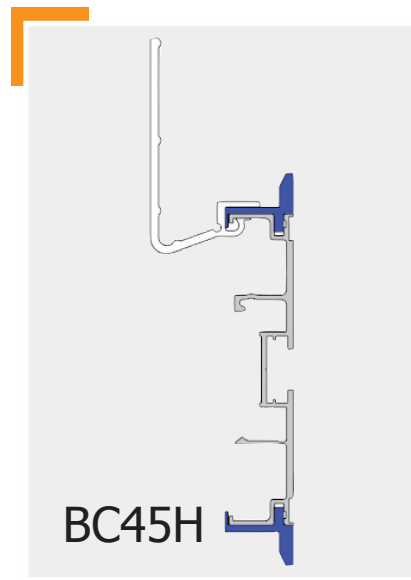
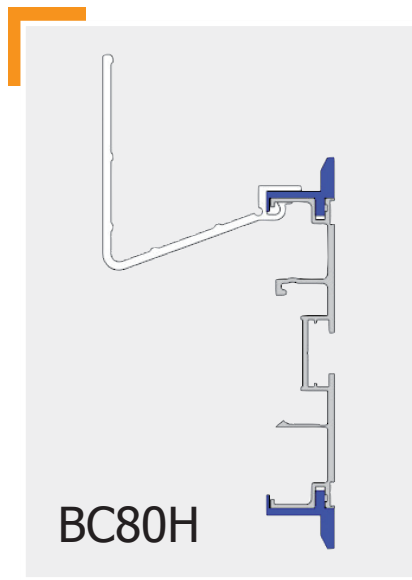

Figure 23

September 2014



240508



E257460





The vertical run is not visible behind the profile but the wire is moving above and below making it easy to trace. The benefit of the comb system allows only the wire being pulled to move.

The clear access to the devices allows for an easy maintenance and testing of the components as they clearly stand out (**Fig. 24**).

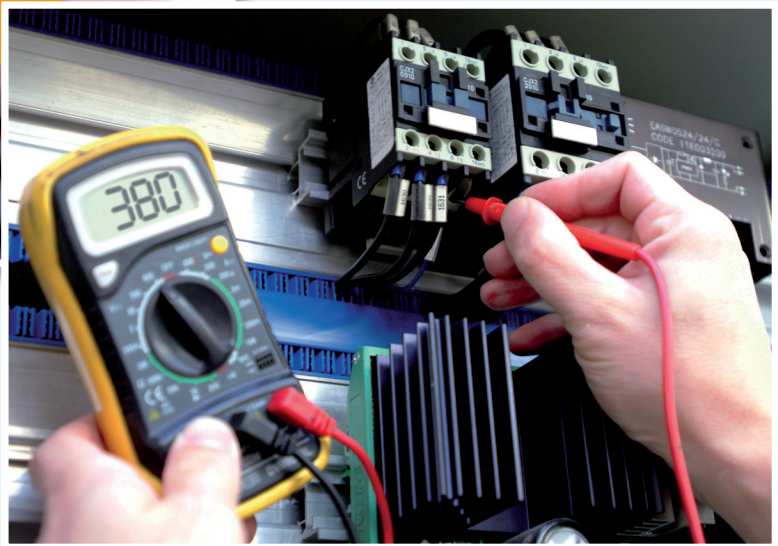
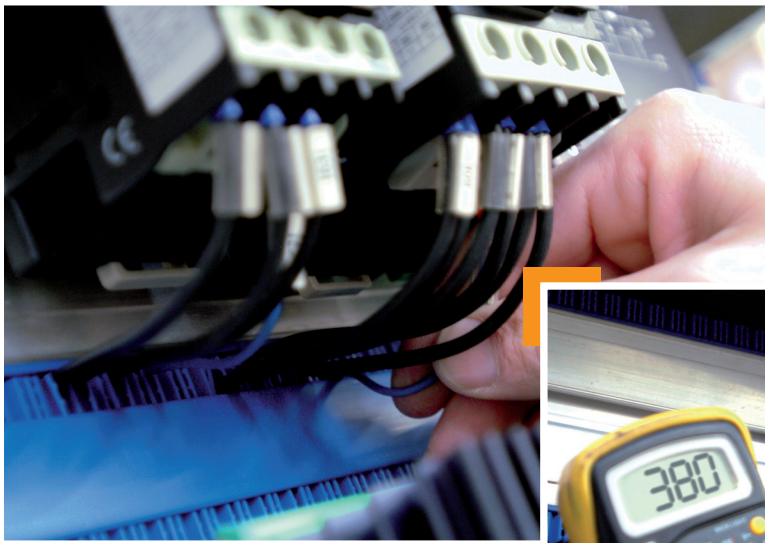

Figure 24

If you have to add a wire it will be easy as the wire will sit in the tray without disrupting the wiring previously done.

**If you need further assistance please contact us at  
(647) 477-2433 or [info@Satienna.com](mailto:info@Satienna.com)**

*Make it Easy, Make it Satie !*